

Elizabethtown University College of Agriculture

EGR 353 – Green Architectural Engineering

Justin Bentzel
Whitney Davis
Munia Kamal
Gavin McQuate

May 6, 2026

SITE PLAN

After surveying the Eastern side of campus, Figures 1 and 2 demonstrate our intended use of the given space. On the left soccer field, we plan to add our major academic building and a pond for community gathering and aesthetics. On the right field we will include a barn with a grazing area for animals, a shed-like lab for surveying and geotechnical equipment, and a greenhouse. We will expand the quad parking to accommodate traffic from these new additions. Additionally, near the solar field there will be two gardens, a community space with a gazebo, and a mini market. Figure 1 illustrates the footprint overlayed against a satellite image from Esri imagery (2013) for geographical context, and Figure 2 removes the background for clarity of buildings labels and pathways. In these images, the red lines show the development area we surveyed, the yellow lines represent walking pathways created to connect buildings, and the blue oval symbolizes a pond.



Figure 1: Geographical Footprint of New University

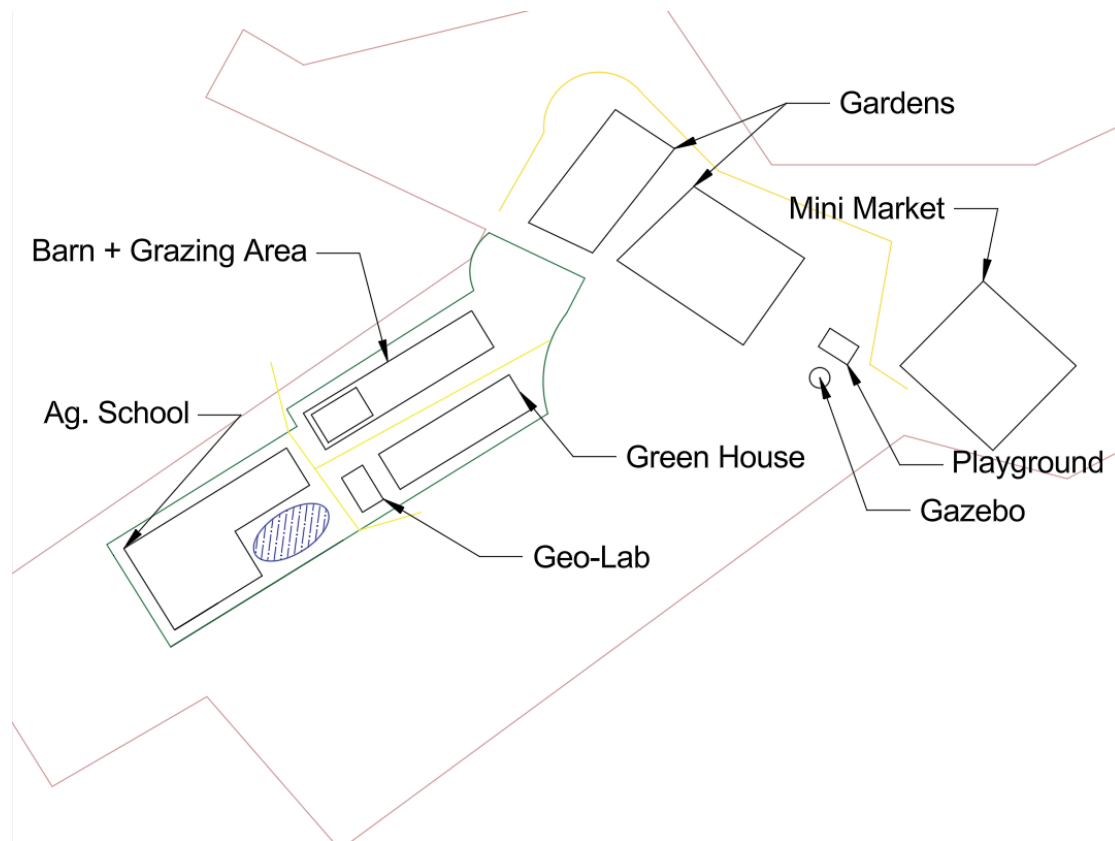

Figure 2: Labeled Drawing of College of Agriculture

ACADEMIC BUILDING – EXTERIOR DESIGN

Figure 3 exhibits the academic building modeled using Revit. Staying in the Vernacular of Etown, we designed this academic building to house an industrial size boiler and farm workshop for the specific classes for the new College of Agriculture. Using an insulated brick exterior wall with cement brick lining makes the building feel in place with Etown while keeping standards of factory temperatures. The ceiling is asphalt tar poured with synthetic layering and leveled off. The pond nearby encourages independent studies of bodies of water and could be considered as a semi-retaining pond to counteract the additional impervious surfaces. On the left side of the boiler room, giant high row windows give ventilation to this workshop while not bringing added lighting that may disturb the room temperature.

Functionality of the boiler room is key for the College of Agriculture to flourish and gather the personnel needed for this school. After research and investigations into how a boiler room functions by viewing a video on the subject [1], we decided to follow this system: first the water flows through a softener, then through chemical cleaning, then into a deaerator, then finally into the Seminole 3-pass Wetback Firetube Boiler. For these machines to operate, they will need water lines and natural gas intake; therefore, we will apply safety requirements in proper ventilation and spacing. When designing the building, we kept these limitations in mind and provided additional spacing between machinery and raised the ceiling to allow for potential smoke/steam release ports.

Considering how the outside environment affects the building, we opted to eliminate the negative effects sunlight brings to a factory setting by keeping the windows on the west facing side. In contrast, when thinking about sunlight for our classroom/workshop; we wanted natural sunlight to dominate; therefore, including windows on the south-east facing wall maximizes sunlight and also offers a view of the pond.



Figure 3: Rendered Academic Building with Pond

The psychrometric-style chart, shown in Figure 4, represents the relationship between dry bulb temperature and humidity for a Climate Region 3 environment, with monthly outdoor conditions plotted from winter through summer. Some factors that influence the psychrometric chart are the brick walls, cooling due to the pond, flat roof increasing heating, windows for solar heat, plus light industrial lighting. The monthly points show that winter conditions fall outside the comfort zone and require heating, while summer conditions exceed comfort limits due to higher temperatures and humidity, requiring cooling. Transitional months like May and September fall closer to the comfort zone, where passive strategies such as ventilation and thermal mass can help support comfortable indoor conditions.

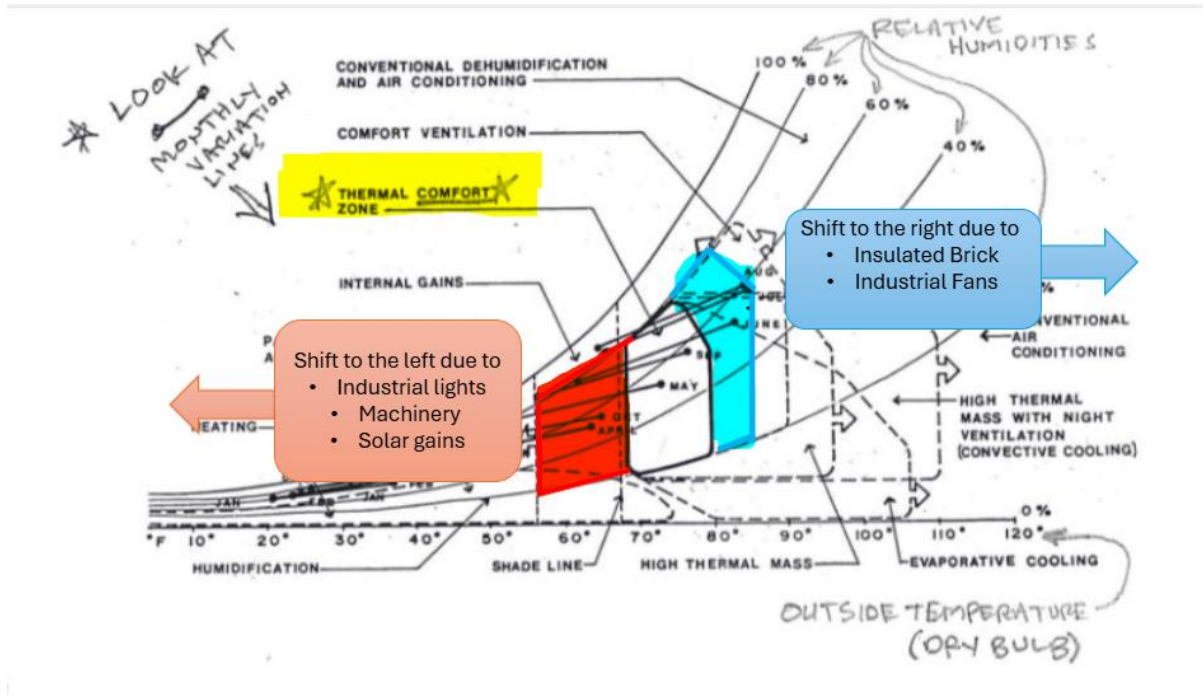

Figure 4: Psychrometric Chart of the Academic Building

BARN WITH GRAZING SECTION – EXTERIOR DESIGN

Figures 5-9 model our proposed barn, developed in Minecraft. The barn, which includes an adjacent grazing area, is located on the right soccer field, closer to the Quads. We propose an animal-lending system in partnership with local farms, allowing professors to incorporate livestock into the agricultural curriculum without requiring the space or long-term resources needed to maintain a full farm year-round.

The barn and adjacent grazing area are intentionally oriented to respond to seasonal variations in sunlight, optimizing both natural daylighting and thermal performance throughout the year. The building incorporates south-facing windows to take advantage of consistent solar exposure. During the winter months, when the sun sits lower on the horizon, these windows obtain maximum solar radiation, enhancing passive heating and reducing the need for mechanical systems. In contrast, during the summer, strategically designed overhangs and awnings limit direct solar gain, mitigating the risk of overheating. Additional shading devices, such as blinds or window shades, provide further control of interior conditions when needed. We incorporate east-facing windows and position the grazing area on the eastern side of the barn to capture early morning light, supporting natural illumination during active morning hours while avoiding excessive heat gain later in the day. Clerestory windows maximize daylight penetration deeper into the barn without sacrificing usable wall space for storage or equipment. These elevated openings reduce glare and maintain privacy while contributing to a more evenly distributed interior light quality.

To address summer cooling, the barn utilizes double-hung windows on opposing walls to facilitate cross-ventilation. Opening both the upper and lower sashes establishes a natural convection cycle where cooler air enters through the lower openings as warmer air rises and exits through the upper openings. This process, enhanced by the Venturi effect, promotes

passive airflow and reduces internal temperatures without mechanical cooling. During the winter, these windows can be sealed to retain heat. Animal placement within the barn further responds to thermal conditions. In the summer, stalls house animals on the north side of the structure, where temperatures remain cooler due to reduced solar exposure. In the winter, they move to the south side to benefit from passive solar heating. Additionally, surrounding vegetation, including strategically placed trees, provides natural shading to further regulate temperature in both the barn and grazing areas.



Figure 5: Isometric View of Barn with Grazing Section



Figure 6: Side View of Barn with Grazing Section



Figure 7: Top View of Barn with Grazing Section



Figure 8: Detailed Exterior View of Barn with Grazing Section



Figure 9: Detailed Exterior View 2 of Barn with Grazing Section

Figure 10 illustrates the psychometric chart for the barn. During summer conditions, south-facing overhangs and shading devices reduce direct solar radiation, lowering interior temperatures. Cross-ventilation enabled by operable double-hung windows increases airflow, expanding the comfort zone to the right by allowing occupants and animals to better tolerate higher temperatures through enhanced convective cooling. Vegetation surrounding the barn and grazing area provides additional shading, slightly reducing air temperature, shifting the comfort zone to the right. However, this also increases humidity, which shifts conditions down and to the left on the chart. In the early morning, east-facing openings introduce cooler air and daylight without excessive heat gain, helping stabilize indoor conditions. The blue thermal comfort zone in Figure 10 represents these summer conditions.

During winter conditions, increased solar gain through south-facing windows shifts conditions to the left toward the comfort zone by enhancing passive heating. However, occasional wind exposure around the structure may introduce slight cooling effects in addition to cold outdoor climate, thus shifting the comfort zone slightly back to the right. The ability to seal windows reduces unwanted cold air infiltration, helping retain heat and maintain more stable indoor temperatures. Animal placement on the south side of the barn further benefits from direct solar exposure, contributing to additional internal heat. The red thermal comfort zone in Figure 10 represents the effects of winter conditions.

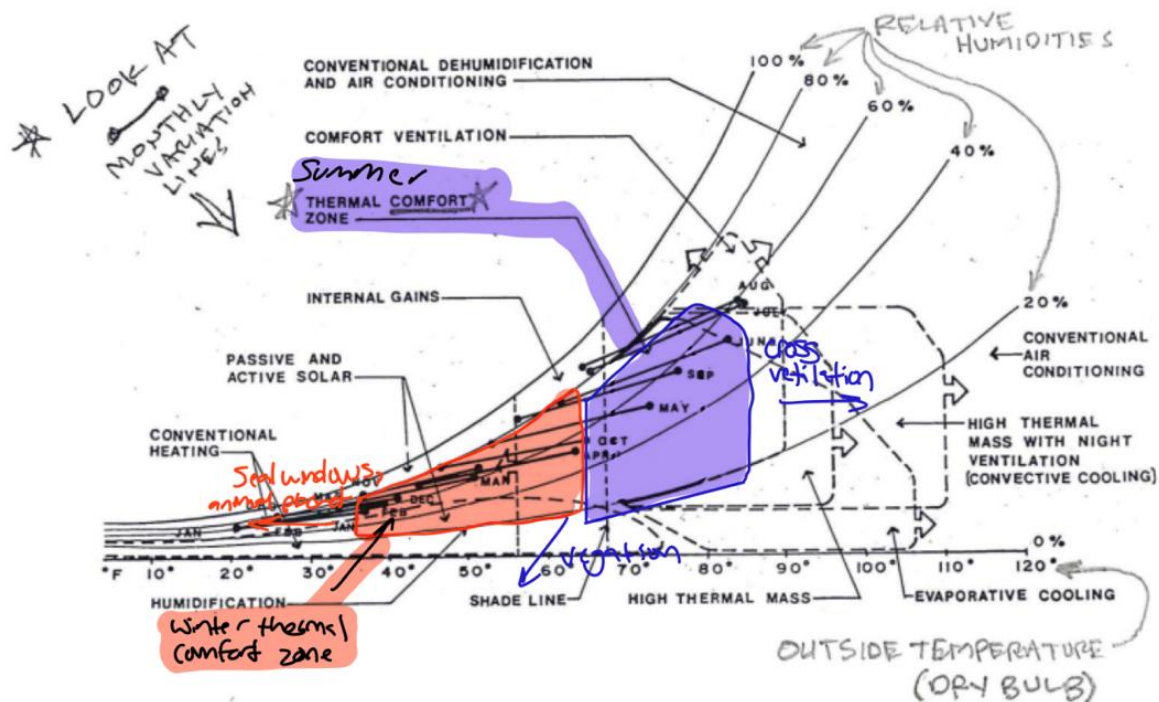

Figure 10: Psychometric Chart for Barn with Grazing Section

GAZEBO – EXTERIOR DESIGN

Figure 11 models our proposed gazebo, developed in Autodesk Inventor. Located near the existing solar field in the proposed community space, this gazebo serves as a flexible outdoor gathering area for community members, students, and faculty. The design incorporates ambient lighting incorporated into the structure powered by on-site solar panels. While not

shown in the model, our team proposes built-in bench seating along the interior perimeter to support gathering and study, positioned to take advantage of shaded conditions and natural airflow.

The gazebo orientation responds to seasonal variations in sunlight to best balance natural daylighting with thermal comfort. As an open-air structure, it maximizes daylight penetration throughout the year; however, its roof design plays a critical role in moderating solar exposure. During the summer months, when the sun sits at a higher angle, the roof provides consistent shading to reduce direct solar radiation and prevent overheating within the occupied space. In contrast, during the winter, the lower sun angle allows more direct sunlight to enter beneath the roofline, creating a more comfortable environment despite colder ambient temperatures.

The structure also takes advantage of passive ventilation to maintain comfort during warmer months. With open sides, the gazebo allows for unobstructed airflow, promoting natural cooling through cross-breezes. The placement of the structure near open fields further enhances wind exposure, supporting continuous air movement and reducing heat buildup. This natural ventilation eliminates the need for mechanical cooling while maintaining a comfortable environment for occupants. Material selection further contributes to thermal performance. Light-colored and reflective roofing materials minimize heat absorption, while the surrounding landscape, including nearby vegetation, provides additional shading and helps reduce localized temperatures through evapotranspiration. Together, these strategies ensure that the gazebo remains a usable and comfortable space across seasons.



Figure 11: Exterior View of Gazebo

Figure 12 illustrates the psychrometric chart for the gazebo. During summer conditions, shading from the roof reduces solar radiation and lowers the effective temperature. The open-air design increases airflow, which expands the comfort zone to the right by allowing

occupants to tolerate higher temperatures because airflow helps them cool off faster. Vegetation and evapotranspiration provide additional cooling, slightly lowering air temperature, which shifts the comfort zone to the right. However, these features also increase humidity, which shifts the comfort zone down and to the left. During winter conditions, solar gain from the lower sun angle introduces additional radiant heat, shifting the comfort zone toward cooler conditions. However, increased wind exposure can make the atmosphere feel colder, shifting the comfort zone slightly back to the right. Since the gazebo is an open-air structure with minimal seasonal control over heating and cooling strategies, a single, unified comfort zone represents both summer and winter conditions.

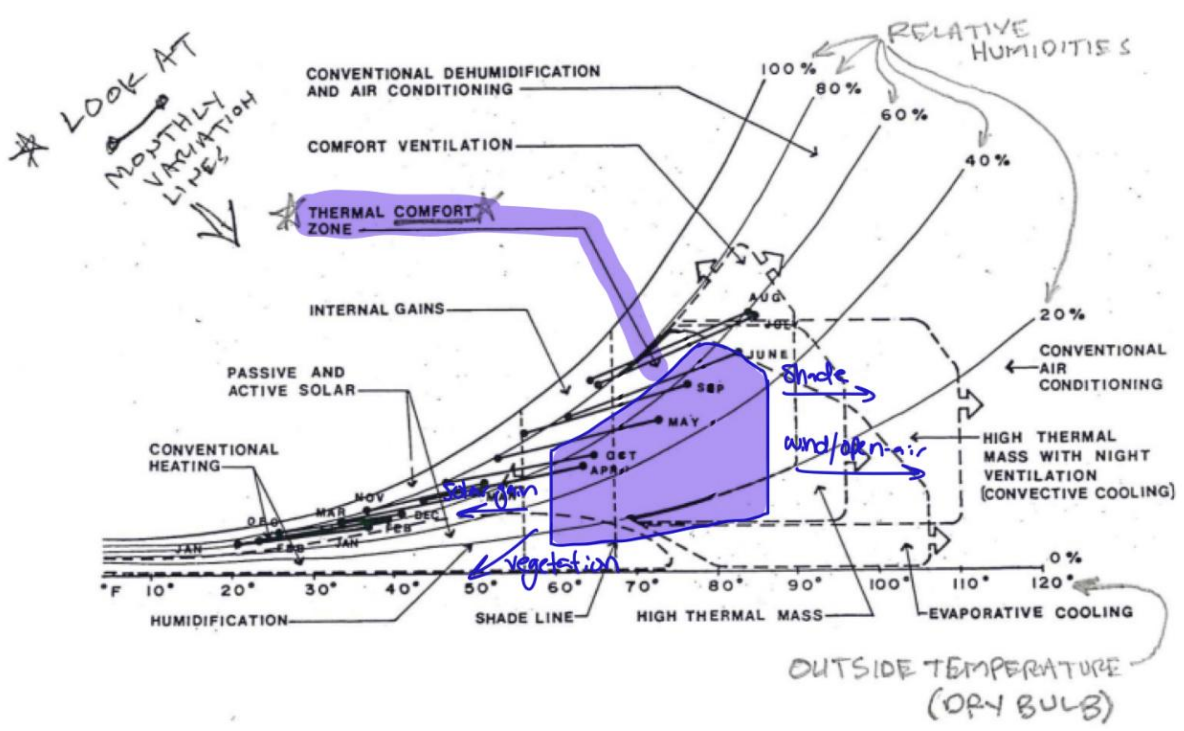

Figure 12: Psychrometric Chart for Gazebo

MINI-MARKET – EXTERIOR AND INTERIOR DESIGN

Figures 13-16 display the proposed Mini-Market, developed and modeled in Minecraft. Located as the eastern-most building within our site plan, the mini market will act as a source of food, gasoline, and many other products for both the students and staff on our expanded campus, as well as other community members who are in need of local goods.

The mini-market orientation directly responds to the seasonal variations in sunlight to balance the natural daylight with our target interior temperature of around 20 degrees Celsius. Figure 16 displays the high-clearance glazed windows, which minimizes daylight penetration throughout the entirety of the year, further reducing the required electrical load for artificial lighting inside during the day. During the hotter summer months when the sun lays at a higher angle, the roof overhangs provide consistent shading for the customers. During the winter, the lower sun angle allows direct sunlight to enter beneath the flattened roofline, providing a passive solar heating component to the design that maintains a comfortable environment despite the colder central Pennsylvania outdoor temperatures.

The mini-market also utilizes internal volume and passive strategies to maintain a desired comfort during the warmer months. Although the market is an enclosed space, the high ceilings and strategic layout of the interior help facilitate air movement, further promoting natural ventilation throughout the structure. This convective cooling helps mediate the heat buildup occurring due to kitchen equipment and refrigeration units.

The material selection the further contributes to the thermal performance of the building, as well as it allows the franchisee to be able to market their brand while operating within a LEED Platinum certified campus extension. Figures 13 and 15 help magnify the surrounding landscape and custom vegetation providing localized cooling through evapotranspiration. Additionally, the roof-mounted solar array seen in Figure 15 serves multiple purposes, including the capture of renewable energy, while also acting as a thermal barrier for the roof. All together, these strategies help ensure that the mini-market remains as an energy-efficient and comfortable space across all seasons for all the members of the Elizabethtown community.



Figure 13: Overview of Mini-Market Design



Figure 14: Close-up of the Front of the Mini-Market



Figure 15: Back Side of the Mini-Market and the Solar Array Roof



Figure 16: Interior of the Mini-Market

The psychometric analysis seen in Figure 17 illustrates how the mini-market's design expands the standard comfort zone through targeted passive strategies. By accounting for the heat produced by kitchen equipment and refrigeration, the left-leaning expansion allows the market to maintain the desired temperature baseline even as outdoor temperatures drop into the 50–60-degree Fahrenheit range. During the winter, the large-format glazed windows capture low-angle solar radiation, effectively shifting the range further to the left. The roof overhangs establish a critical shade line, blocking peak summer irradiance and preventing the interior from tracking with the high dry-bulb temperatures of July and August. Finally, the high internal volume and open layout help facilitate the natural ventilation of the building, extending the right-leaning boundary of the comfort zone to mitigate the high humidity of central Pennsylvania summers through increased air velocity. Together, these design modifications demonstrate a design that remains thermally stable without constant reliance on conventional mechanical systems.

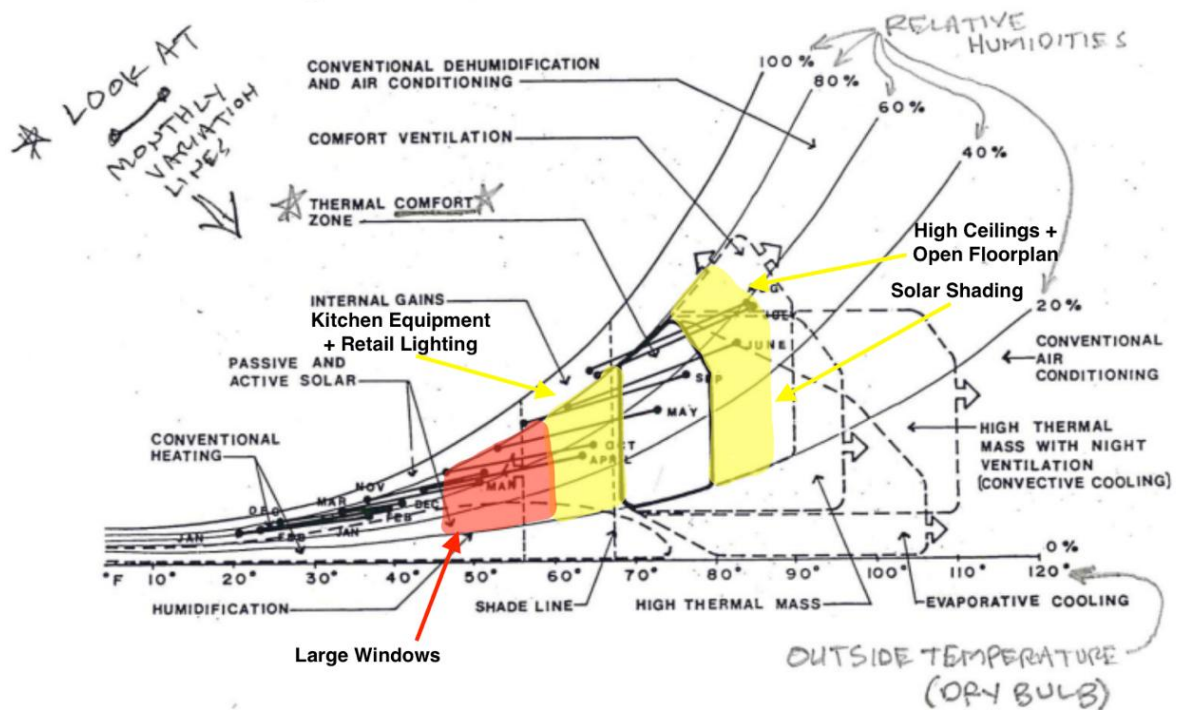

Figure 17: Psychrometric Chart for Mini-Market

ACADEMIC BUILDING – ARCHITECTURAL DETAILS

When designing the Academic Building, we prioritized creating a functional and intentional space to make our building as efficient as possible. Using knowledge from Green Architectural Engineering and outside resources, we can connect each lesson to a part of this influential building. In Figures 18-20 we show a detailed interior of the academic building without piping and electrical work. For these features not defined in our detailed floor plan, we plan on incorporating AIA Graphics and Standards set in the industry to guide our understanding and mold our design. We accounted for needed space by providing extra room around each of the machines and following similar spacing shown in the guiding video [1].

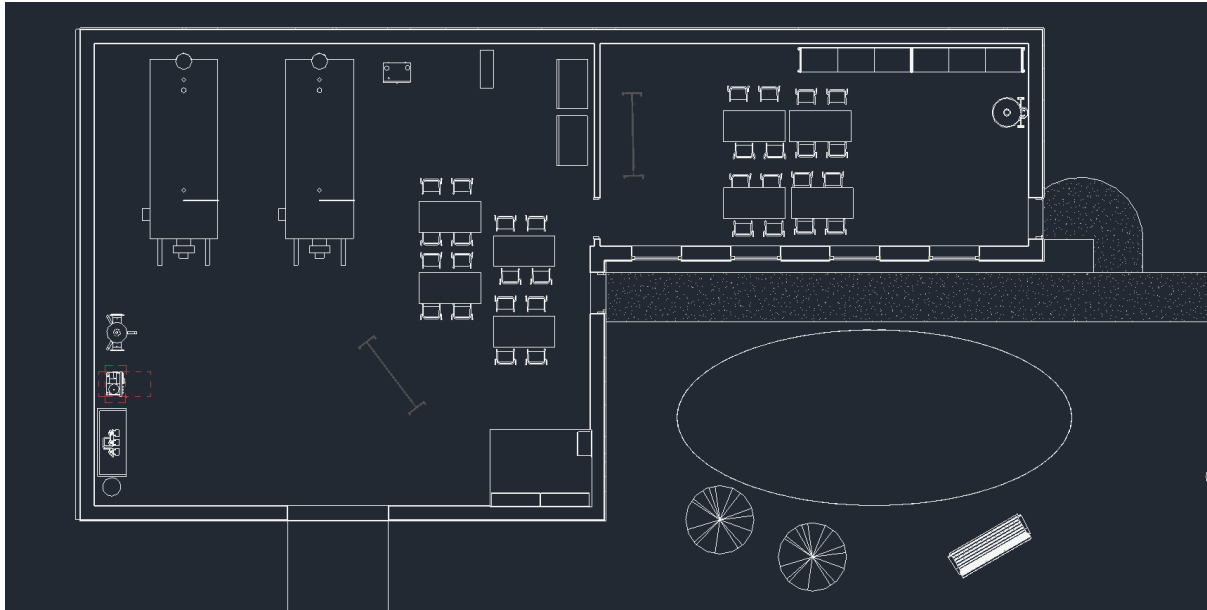

Figure 18: Detailed Boiler Room (left) and Workshop/Classroom (right)

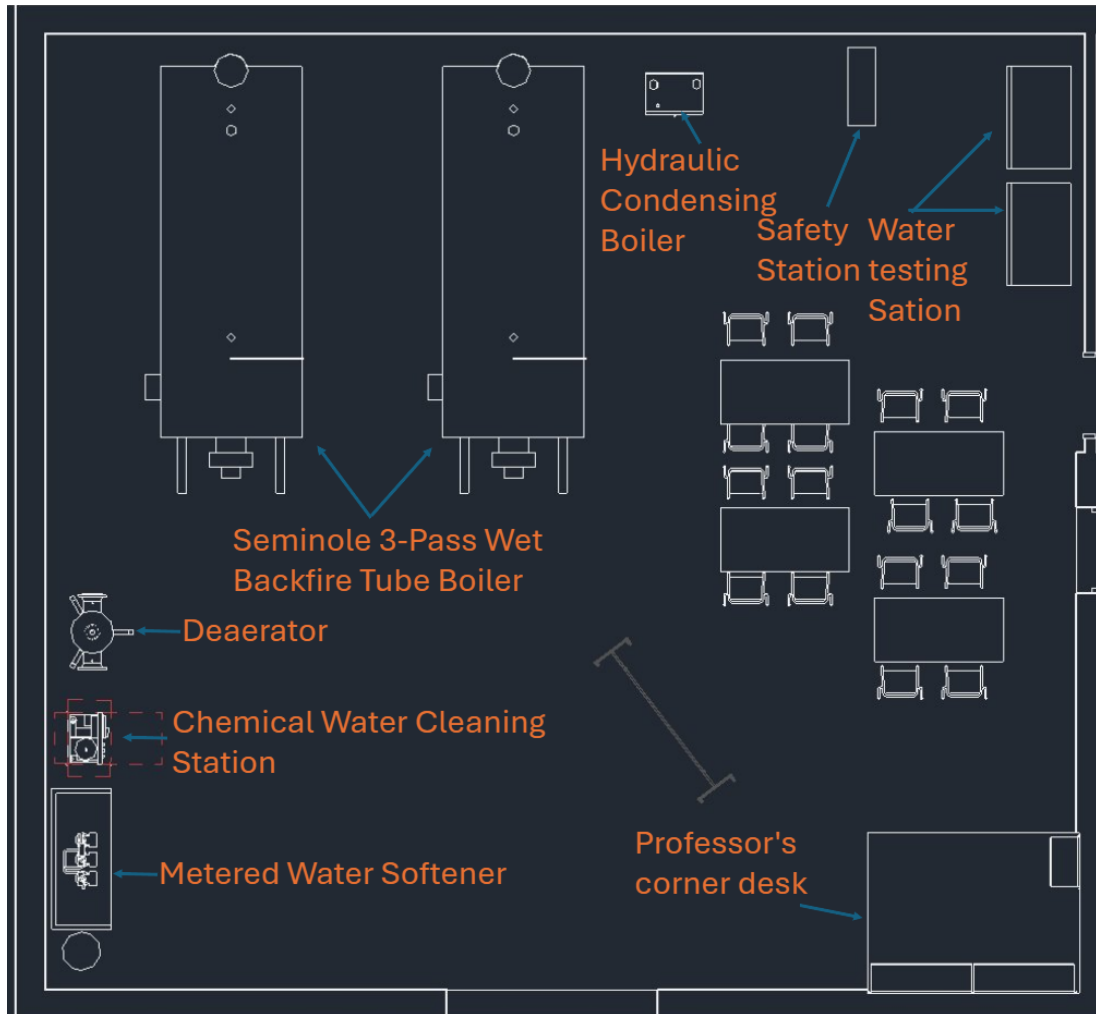

Figure 19: Labeled Boiler Room Detail

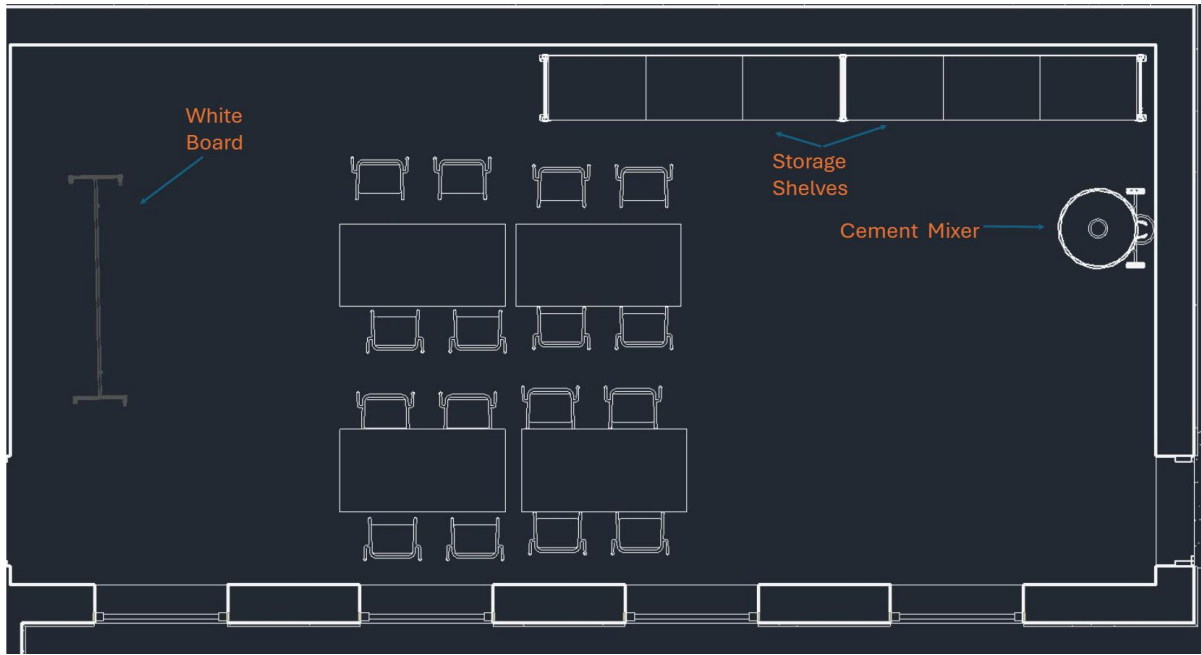

Figure 20: Labeled Workshop/Classroom Detail

Ventilation is crucial for any building but is most important in an industrial setting, especially when students from different backgrounds and previous conditions utilize the space. Using a combination of ASHRAE standards 62.1 and NBBI (National Board of Boiler and Pressure Vessel Inspector) standards of pressure and circulation [2], we can effectively use active and passive ventilation in our building. High-rise windows represent one of our passive ventilation strategies; these windows automatically open upon reaching certain pressure and CO₂ levels. For our active ventilation components, Figure 21 explores how we use AIA Graphics for industrial boiler rooms design to effectively and safely account for any additional safety measures that may cause potential health risk on students and staff. HVAC is crucial to the whole process to avoid mold and asbestos, using Figure 22 we can follow the standard system for a boiler room. Additionally, automatic blinds for the classroom/workshop windows benefit from the thermal envelope and moisture content that can affect temperatures and humidities.

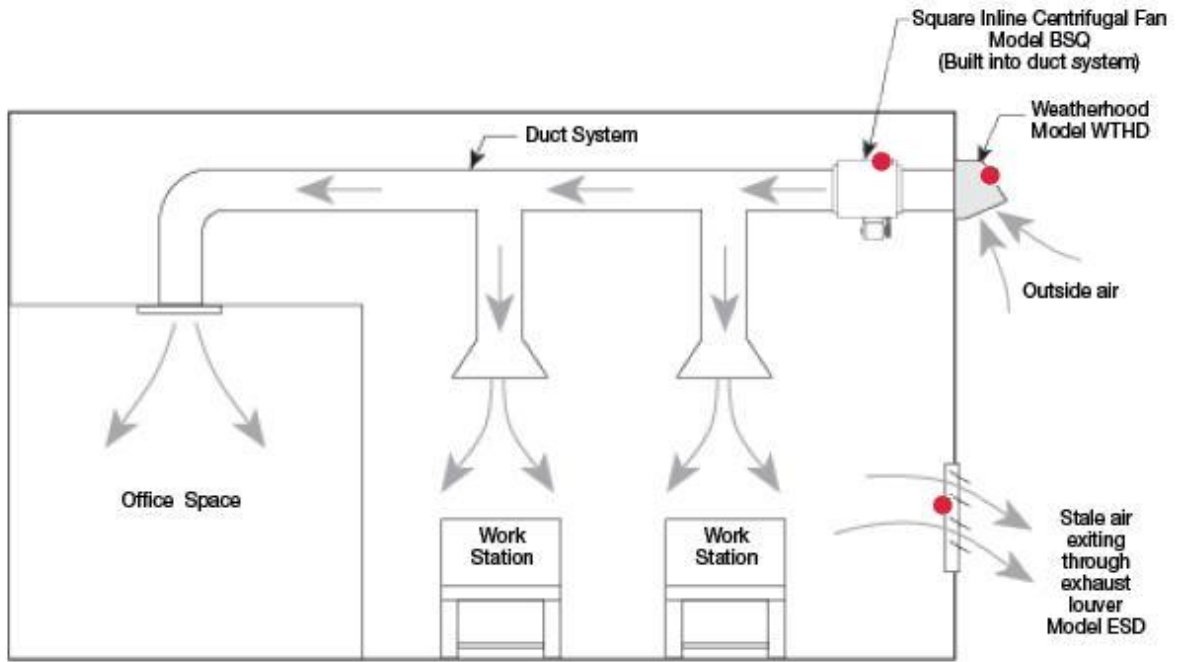

Figure 21: Architectural Diagram of Greenheck product [3]

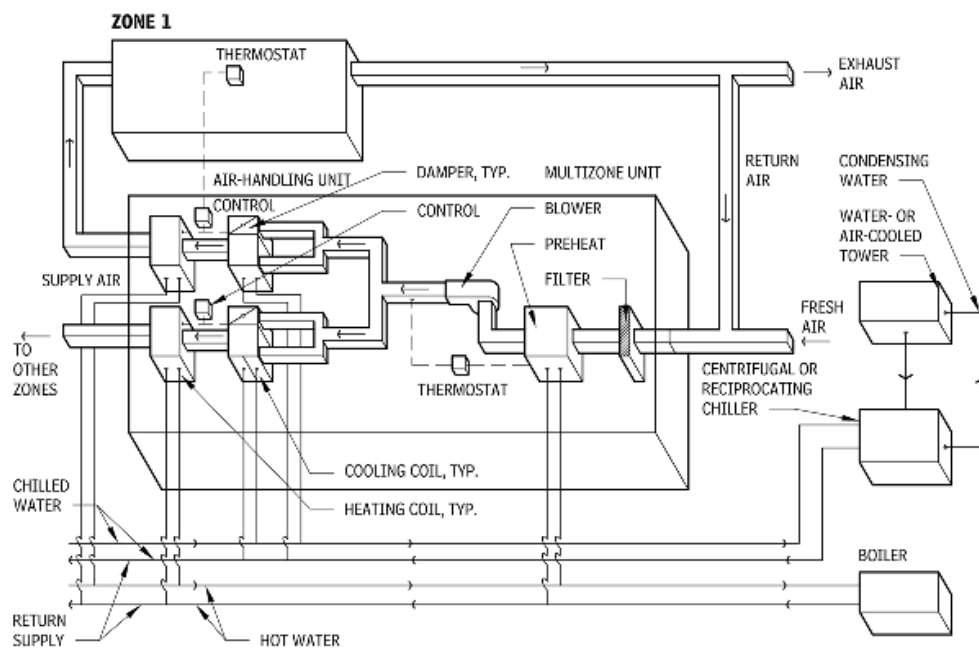

Figure 22: HVAC System for a Boiler Room with a Cool Deck Bypass

This structure's height and orientation allow for the inclusion of rooftop solar panels. The building faces south-east, which optimizes solar production in winter and summer months. Figure 23 shows the decking required to angle the solar panels and secure their footings.

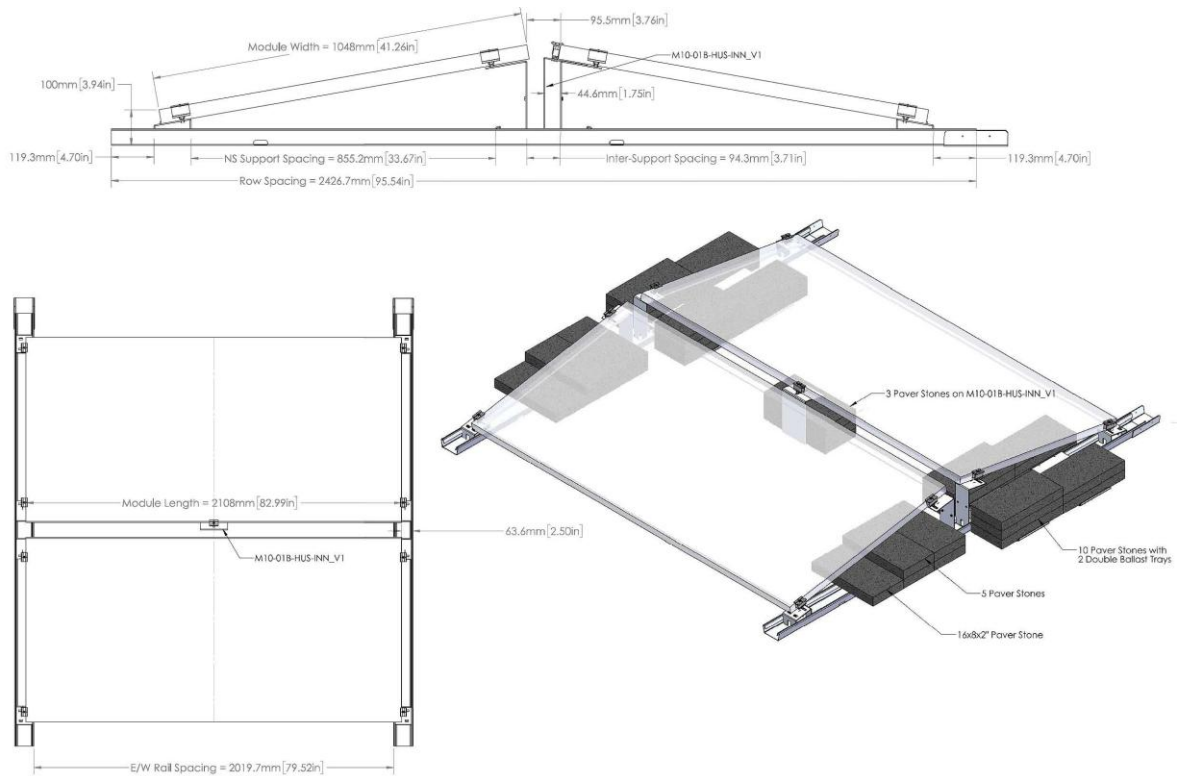

Figure 23: Detailed Design Specification for Industrial Solar Panel Decking System

Concerns regarding visibility of hands-on activities highlight the importance of interior lighting for both spaces. Figure 24 shows detailed and optimized spacing and height of lighting for an industrial setting. Using this, we can follow the precedent for our boiler room to accomplish efficient and comfortable lighting design. Additionally we take inspiration from lighting systems present in the Fabrication Lab on campus for the classroom/workshop.

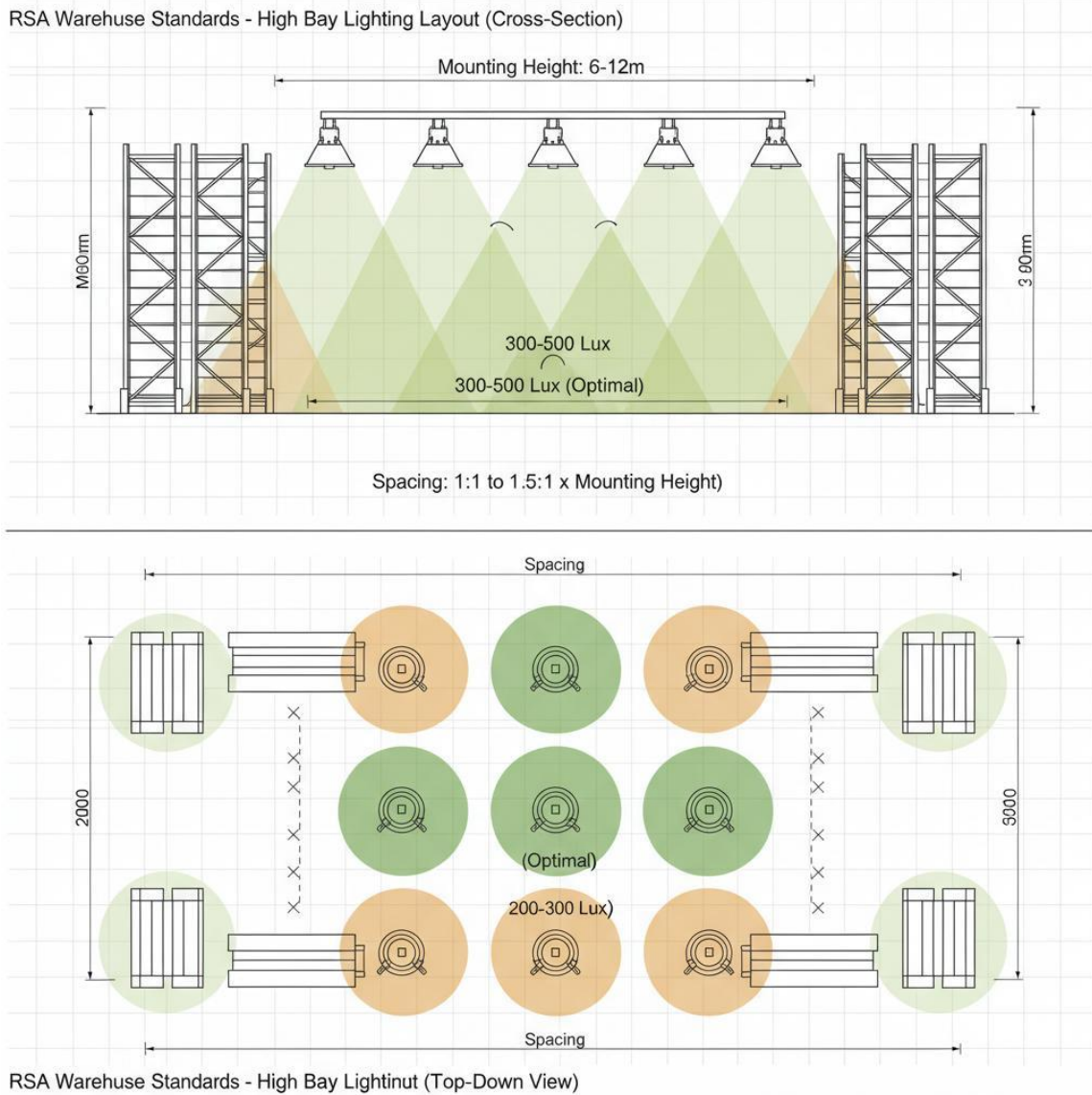

Figure 24: Detailed Graphic on Optimal Lighting in an Industrial Setting

Foundation is a major part of the entire structure's success and stability. Without knowing the specific soil properties that the building will be located on, we'll assume the standard established by AIA Graphic and develop our design according to Figure 25. This architectural detail gives an understanding of the importance of concrete slabs and piping networks underneath the structure. Until we can collect soil samples and obtain information on existing structures underground, this is the best conclusion to consider while designing.

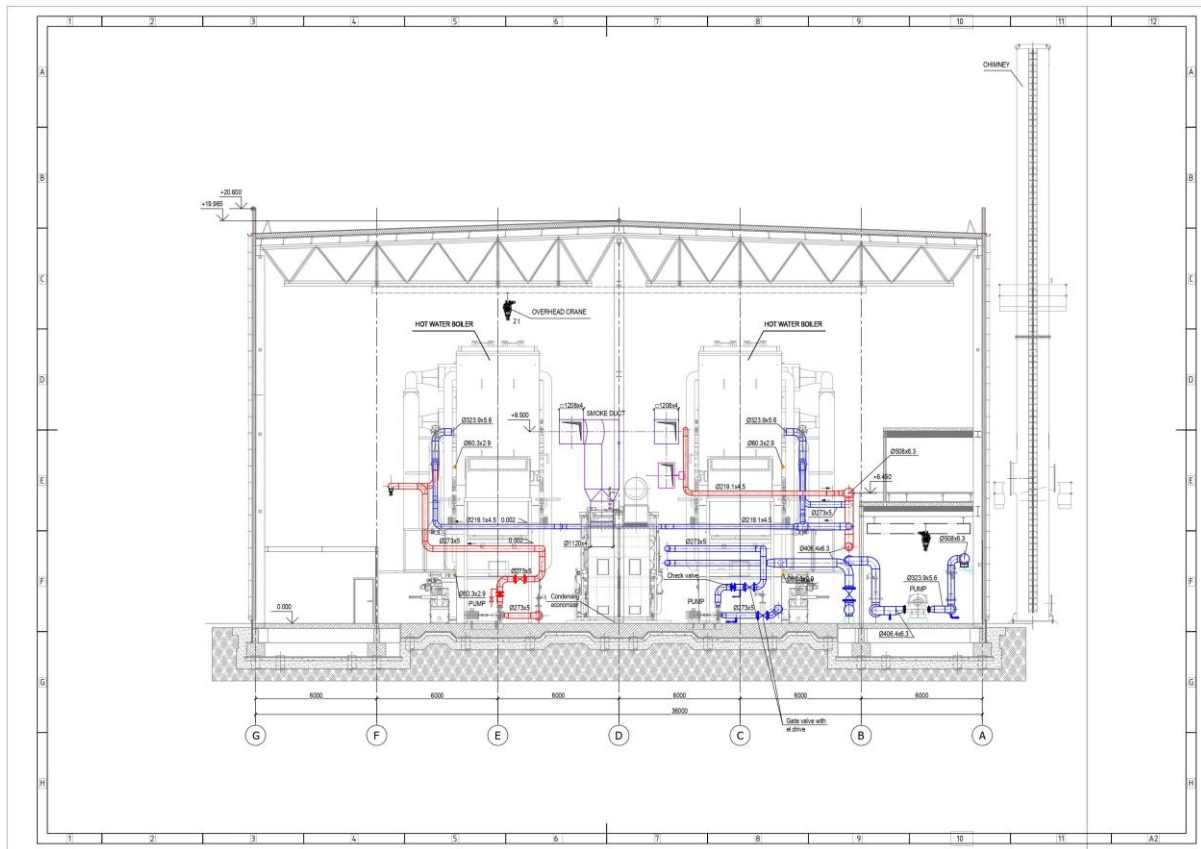

Figure 25: Detailed Visual Showing a Full Boiler Room Including Foundation

The solar path over our designed academic building played a large role in its design and placement. Figure 26 displays the varying impact the sun has on an interior space throughout the entirety of a year. Large windows help promote natural lighting and passive solar within our design. The large garage door also promotes passive solar, acting as a large-scale variable window into our boiler room. Furthermore, the indirect sunlight and shading provided by the large, covered roof allows for passive cooling and shade to develop within the boiler room and the classroom. Controlling diffused light within our design will allow our structure to perform at a highly passive level throughout the entire year. The lectures covering Chapters 6, 7, and 9 display the reasoning behind these implementations for our design. Including passive solar and passive shading and cooling based on the solar path allows our building to become a self-mediating learning area for our future students and staff.

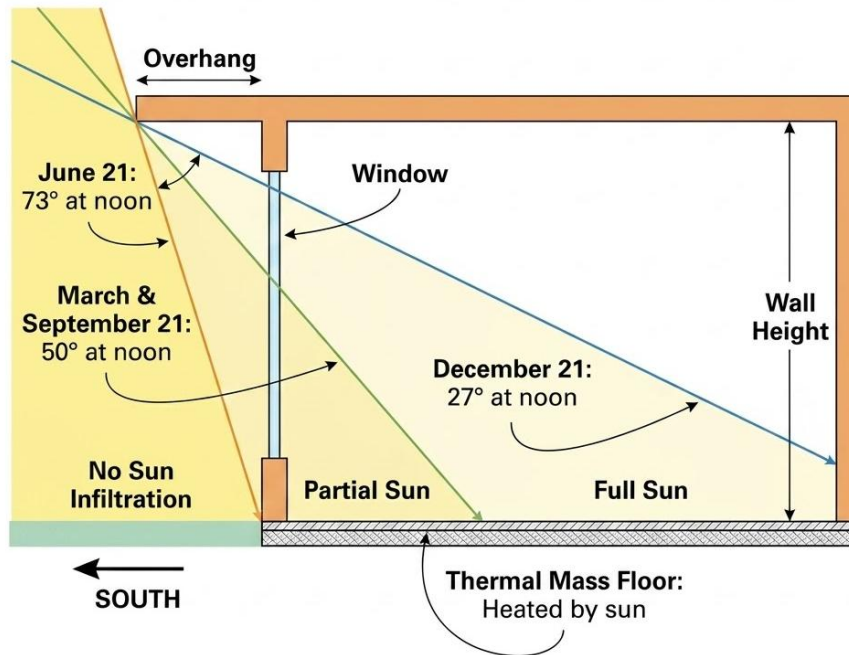

Figure 26: Visual Displaying how the Local Solar Path Effects Solar and Shading

Classroom acoustics are highly important to create an effective learning environment for the students utilizing our new campus. Figures 18-20 outline the floorplan for our designed classroom. Described in the guest lecture by Dr. K Roy, the maximum reverberation time for a classroom is 0.6 seconds, or else the speakers' voice will become interfered with by the bouncing sound, causing confusion for the listening students. Balancing absorption, isolation, and reflection within our classroom will promote a functional learning space for our students.

Within our academic building design, as previously stated, the psychometric chart, shown in Figure 4, visualizes how winter and summer conditions fall outside the comfort zone, requiring heating in winter and cooling in summer. Transitional months approach comfort conditions where passive strategies such as ventilation and thermal mass are effective, with overall performance influenced by envelope and site factors, including walls, roof, glazing, and nearby water. The class lecture on Chapter 5 of our textbook explains these factors and how they interact with each other. This analysis is important within our design to best understand how the prospective users of our campus will feel comfort-wise within the academic building.

LEED CERTIFICATION

LEED v4.1 requires a minimum of 80 credits to achieve Platinum status for Building Design and Construction (BD&C), Appendix A tabulates the total credit earnings for our design. In total, our plan scores 85 definite credits in the green column and 12 potential credits in the yellow column for objectives we hope to implement but are not guaranteed. We plan to achieve “integrative process” credit by analyzing and establishing specific goals for water-related systems and health and well-being. For example, at least 50% of goods sold in the mini-market should consist of locally grown produce from the gardens and animal products from the barn; this promotes the health of college students and surrounding residents.

Locating this new university within the boundary of a Platinum certified Neighborhood Development under the LEED v4 rating system earns us 16 LEED credits in the Location and Transportation category. We design for “sensitive land protection” by developing the footprint on previously developed sites as well as avoiding the wildlife meadow. Additionally, building in an area with a high density of surrounding infrastructure promotes diverse use buildings, walkability, and supports local economies. Similarly, access to quality transit via the Elizabethtown Amtrak station and designated bicycle parking and maintenance stations at each major building limit the need for vehicular traffic. Finally, the expansion of the Quad Parking lot will dedicate at least 1% of total parking spaces parking for car share vehicles and 10% for EV Ready spaces.

For accreditation in the Sustainable Sites category, well over 30% of our foot plan in Figure 1 consists of outdoor space. The two gardens dedicated to local food production, outdoor study spaces, the gazebo in Figure 11, and the educational center overlooking the Wildlife Meadow inspire a connected and open community. We will preserve the existing wildlife meadow and native habitat areas with the hope of implementing restoration. Tree-lined pedestrian pathways will link all development zones; these sidewalks incorporate energy-efficient lighting to reduce light pollution. We minimize heat island effects through shaded walkways, choosing pavement and roofing materials with high solar reflectance, and green roofs.

Water efficiency is essential for LEED certification of building designs. Therefore, to optimize our outdoor water usage, the two gardens in will utilize a rain water irrigation system to hydrate the crops with moisture sensors to avoid overwatering. Choosing the plant species mindfully and rotating crops based on primary growth months also helps reduce water usage. We hope to achieve partial LEED credit for minimizing indoor water use to 35% of the baseline with sensor operated faucets in the academic building and the mini-market; this prevents excessive usage from accidentally leaving the sink running. However, we cannot guarantee water reduction in the barn or lab areas due to washing animals and equipment. Additionally, we plan to recycle water from condensation in the greenhouse and rainwater with a collection system. Permanent water meters that measure the total potable water use for the building and associated grounds ensure the project continues to meet requirements.

Using the existing on-site solar array for power prioritizes renewable energy while optimizing each building’s energy efficiency. Selecting high – efficiency HVAC systems which run on

refrigerants with zero ozone depletion potential reduce the negative effects of greenhouse gasses. This attributes to our LEED Platinum Certification in the Energy and Atmosphere (EA) category. Reflective materials for pavements and roofing reduce the heat island effect which limits the need for excessive cooling. We plan to install LED lighting in all buildings and use automatic light sensors in the academic building to minimize our design's energy consumption. The layout of our foot plan includes south facing structures to maximize the early morning daylight in classrooms; thus, our design takes advantage of natural resources such as daylight for lighting classrooms and open ventilation in the barn area. To ensure the operation meets energy requirements in the long term, we intend to comply with Fundamental and Enhanced Commissioning and Verification specifications as well as establish monitoring procedures for performance evaluations. Some procedures include energy metering.

Waste reduction both during and after construction plays a key role in environmental conservation. LEED requires careful consideration of Materials and Resources for Building Construction. Since landfills majorly influence the production of greenhouse gases in the atmosphere, our design provides dedicated receptacles for recycled materials throughout every building and along walking paths. Additionally, we will develop a waste diversion plan to follow during construction of the project as well as during demolition of the three existing houses in the area planned for our mini market. We hope to reuse at least 25% of materials from these existing structures. Waste management along with opting for local, ethically sourced products with Environmental Product Declarations (EPDs) helps us achieve credit towards Raw Material Sourcing and Life-Cycle Impact Reduction.

To achieve minimum indoor air quality performance, all site elements will meet ASHRAE 62.1 ventilation standards. The academic building, lab, and mini-market will use mechanical ventilation with outdoor air monitoring, while the greenhouse, barn, and gazebo will rely on natural ventilation through operable windows or open-air design. Our development controls environmental tobacco smoke through no-smoking signage and restrictions within 25 feet of building entrances. Enhanced indoor air quality strategies include providing outdoor air access to 75% of regularly occupied spaces, CO₂ monitoring, MERV 13+ filtration, boot cleaning stations near the barn and lab, and vapor barriers in buildings facing the pond to prevent mold growth. We will encourage low-emitting materials, such as low-VOC paints, adhesives, flooring, and wall panels to reduce indoor contaminants. An indoor air quality construction plan protects HVAC systems during installation and includes air testing prior to occupancy. HVAC systems with individual temperature controls and shaded outdoor gathering spaces support thermal comfort. Interior lighting will be adjustable in color and brightness, while large windows, open layouts, and the greenhouse maximize daylight. Users benefit from quality views of the aesthetic pond, gardens, and landscaped areas, as well as experience acoustic comfort through sound insulation and site zoning, with the barn, lab, and garden located at a distance to minimize noise transmission.

Finally, this plan earns 3 Regional Priority Credits because it implements ideas for Surrounding Density and Diverse Uses, Rainwater Management, and Protect or Restore Habitat. We hope to optimize energy performance but cannot guarantee improved performance this early on in development. LEED bases these credits on the design criteria

deemed a priority by Lancaster County. Collectively, these strategies create an efficient, sustainable design focused on quality of life between campus and community; we fulfill the goals of LEED v4 Building Design and Construction and position the project for LEED Platinum certification.

References

- [1] WARE Boilers, “How does a modern boiler room really work? Find out on this expert guided tour - The Boiling Point,” *YouTube*. Sep. 18, 2023. [Online]. Available: <https://www.youtube.com/watch?v=2K3rXPH3sJk>
- [2] “Combustion Air Requirements: The forgotten element in boiler rooms.” <https://www.nationalboard.org/index.aspx?ID=191&pageID=164&>
- [3] “Manufacturing | Greenheck.” <https://www.greenheck.com/shop/resources/typical-installations/manufacturing>

Appendix A – LEED Building Design and Construction (BD&C) Plan Check sheet



LEED v4 for BD+C: New Construction and Major Renovation Project Checklist

Project Name: Elizabethtown University College of Agriculture
Date: May 6, 2026

Y	?	N	Integrative Process	1
1			Integrative Process	1
26 0 0 Location and Transportation				
16			LEED for Neighborhood Development Location	16
1			Sensitive Land Protection	1
0			High Priority Site	2
3			Surrounding Density and Diverse Uses	5
3			Access to Quality Transit	5
1			Bicycle Facilities	1
1			Reduced Parking Footprint	1
1			Green Vehicles	1
7 2 0 Sustainable Sites				
7			Construction Activity Pollution Prevention	10
1			Site Assessment	1
1			Site-Development - Protect or Restore Habitat	2
1			Open Space	1
2			Rainwater Management	3
2			Heat Island Reduction	2
1			Light Pollution Reduction	1
8 3 0 Water Efficiency				
8			Outdoor Water Use Reduction	11
3			Indoor Water Use Reduction	Required
3			Building-Level Water Metering	Required
2			Outdoor Water Use Reduction	2
2			Indoor Water Use Reduction	6
1			Cooling Tower Water Use	2
1			Water Metering	1
17 1 0 Energy and Atmosphere				
17			Fundamental Commissioning and Verification	33
1			Minimum Energy Performance	Required
1			Building-Level Energy Metering	Required
4			Fundamental Refrigerant Management	Required
8			Enhanced Commissioning	6
1			Optimize Energy Performance	18
0			Advanced Energy Metering	1
3			Demand Response	2
1			Renewable Energy Production	3
1			Enhanced Refrigerant Management	1
1			Green Power and Carbon Offsets	2
7 3 0 Materials and Resources				
7			Storage and Collection of Recyclables	13
1			Construction and Demolition Waste Management Planning	Required
2			Building Life-Cycle Impact Reduction	5
1			Building Product Disclosure and Optimization - Environmental Product Declarations	2
2			Building Product Disclosure and Optimization - Sourcing of Raw Materials	2
2			Building Product Disclosure and Optimization - Material Ingredients	2
1			Construction and Demolition Waste Management	2
12 2 0 Indoor Environmental Quality				
12			Minimum Indoor Air Quality Performance	16
2			Environmental Tobacco Smoke Control	Required
2			Enhanced Indoor Air Quality Strategies	2
1			Low-Emitting Materials	3
1			Construction Indoor Air Quality Management Plan	1
1			Indoor Air Quality Assessment	2
1			Thermal Comfort	1
3			Interior Lighting	2
1			Daylight	3
1			Quality Views	1
1			Acoustic Performance	1
4 0 0 Innovation				
4			Innovation	6
0			LEED Accredited Professional	1
3 1 0 Regional Priority				
3			Regional Priority: Specific Credit	4
1			Regional Priority: Specific Credit	1
1			Regional Priority: Specific Credit	1
1			Regional Priority: Specific Credit	1
85 12 0 TOTALS				
Certified: 40 to 49 points, Silver: 50 to 59 points, Gold: 60 to 79 points, Platinum: 80 to 110				Possible Points: 110